

# FIG. 61

## wide mouth beam clamp

3/8" & 1/2"

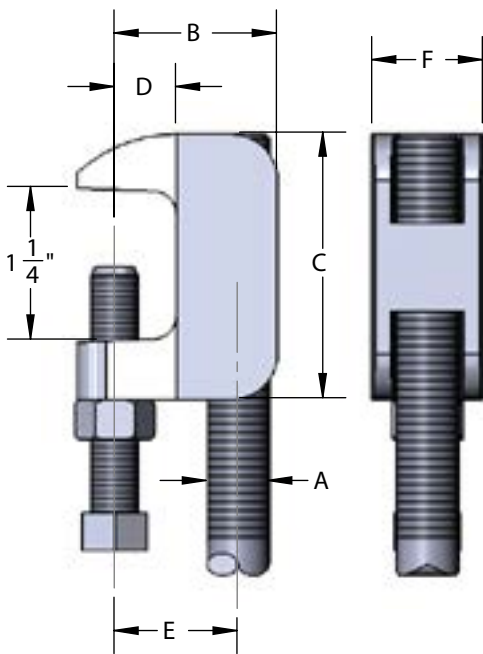

Materials/Finishes	Plain Ductile Iron (61-BK)	Electro-Galvanized (61-EG)
Variants:	N/A	
Service:	Designed to attach hanger rod to the top or bottom flange of a beam or bar.	
Approvals:	U.L. - U.L.C. listed 3/8" and 1/2" (1/2 for 4" IPS max). FM approved for 3/8" only. Complies with Federal Specification A-A-1192A (Type# 19) and Manufacturers' Standardization Society MSS SP-58 and SP-69 (Type# 19).	
Ordering:	Specify figure number, finish and rod size	
Notes:	See MSS SP-69 for proper set screw torque recommendations.	



ROD SIZE A	SET SCREW	B	C	D	E	F	MAX PIPE SIZE	WGT EACH (lbs)	MAX REC LOAD (lbs) INVERTED	MAX REC LOAD (lbs) STANDARD
3/8-16	3/8-16	1-3/8	2	1/2	1	7/8	4	0.55	610	610
1/2-13	3/8-16	1-3/8	2	1/2	1	7/8	4	0.56	750	1130

ROD SIZE A	SET SCREW	B	C	D	E	F	MAX PIPE SIZE	WGT EACH (lbs)	MAX REC LOAD (lbs) STANDARD
5/8-11	3/8-16	1-7/8	2-3/8	5/8	1-3/8	1-1/4	5	0.66	1130
3/4-10	3/8-16	1-7/8	2-3/8	5/8	1-3/8	1-1/4	6	0.83	1130